

SERIES TS 1000

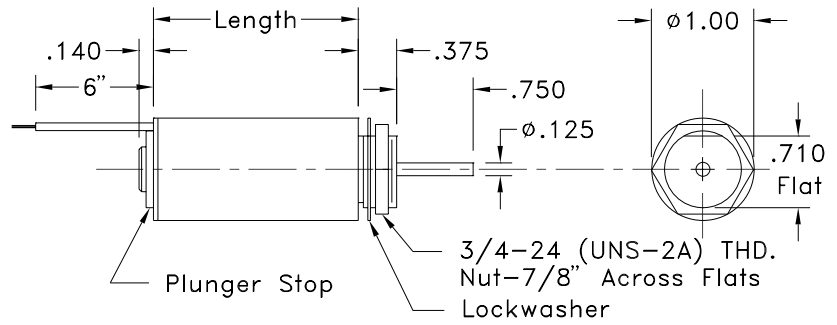
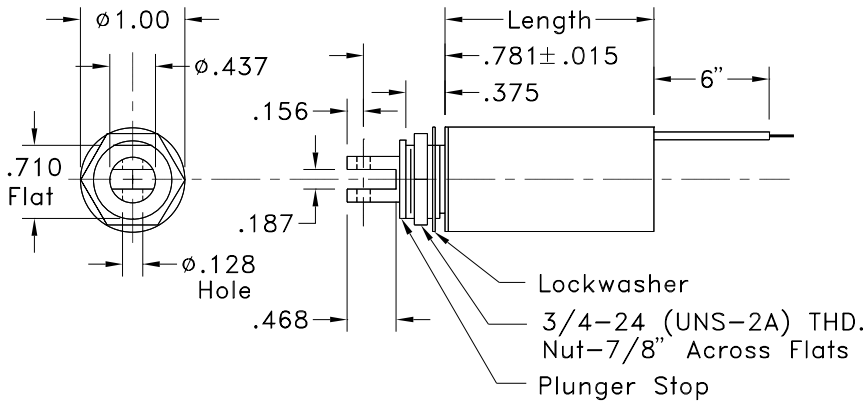
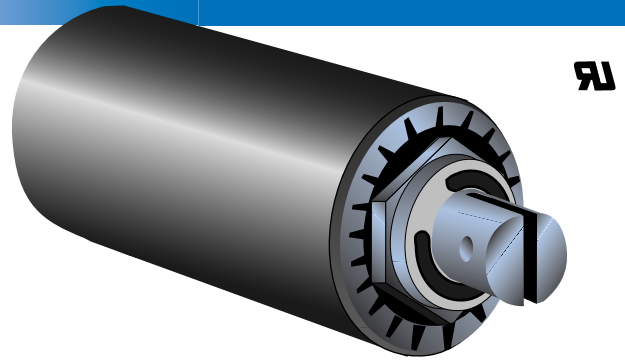

TSP 1000

LENGTH INCHES	1.125			2.000		
	DUTY	CONT.	INT.	PULSE	CONT.	INT.
D.C. POWER WATTS	5	18	66	7.0	40	140
STD. D.C. VOLTAGES	STD. DC COIL RESISTANCE (OHMS)					
6	7	2	N/R	5.1	N/R	N/R
12	28	8	2	20	3.6	N/R
24	115	32	8	82	14.5	4.0
110	N/R	672	183	1720	302	86

SPECIFICATIONS

1. MAXIMUM OPERATING TEMPERATURE: 130° C
2. LIFE EXPECTANCY UNDER OPTIMUM LOAD: 10⁶ CYCLES
3. DIELECTRIC STRENGTH: 1500 V. RMS
4. LEADS: AWG - 22 - U/L 5.4 oz.
5. TOTAL WEIGHT: (153 grams) MAX. 1.6 oz. (45 grams) MAX.
6. PLUNGER WEIGHT: (153 grams) MAX. 1.6 oz. (45 grams) MAX.

Both Models Available with or without Plunger Stop.

INTERMITTENT DUTY CYCLE AT NOMINAL VOLTAGE IS 1 MINUTE MAXIMUM ON TIME AT 10% DUTY. PULSE DUTY CYCLE IS 100 MILLISECONDS ON AT 10% DUTY.

