

# SERIES TS 753

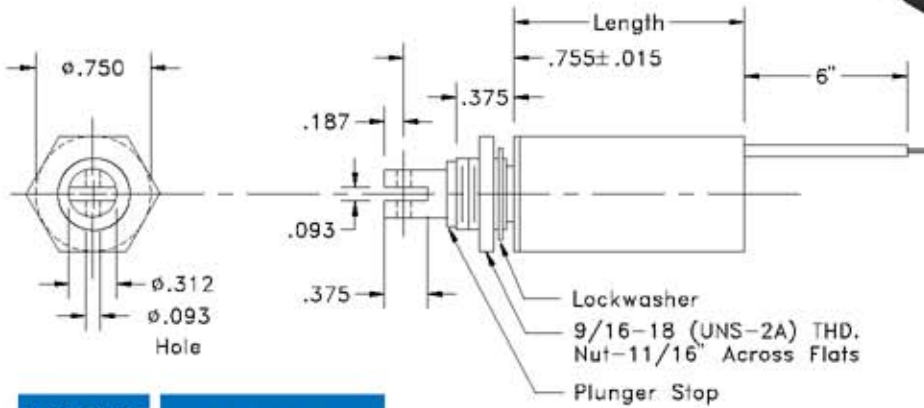

LENGTH INCHES	1.500			
	DUTY	CONT.	INT.	PULSE
D.C. POWER WATTS	5	25	90	
STD. D.C. VOLTAGES	STD. DC COIL RESISTANCE (OHMS)			
6	7	1.5	N/R	
12	28	6	1.5	
24	115	23	6	

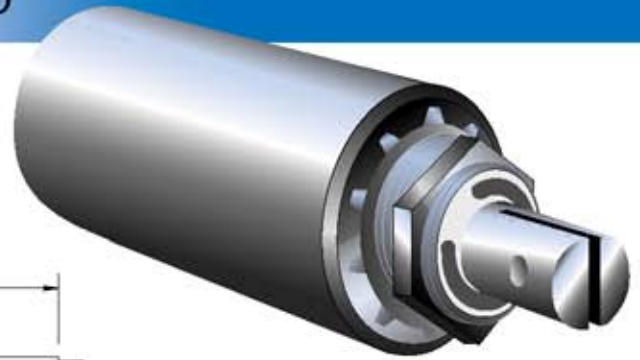
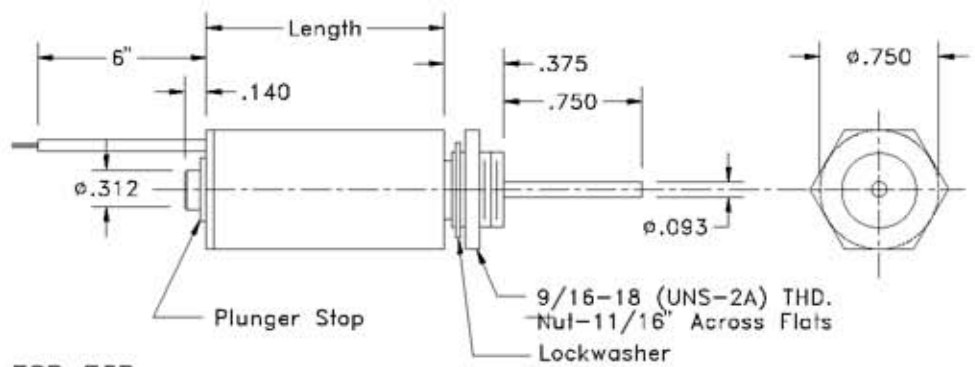

TSP 753

## SPECIFICATIONS

1. MAXIMUM OPERATING TEMPERATURE: 130°C
2. LIFE EXPECTANCY UNDER OPTIMUM LOAD: 10<sup>6</sup> CYCLES
3. DIELECTRIC STRENGTH: 1000 V. RMS
4. LEADS: AWG - 22 - U/L 2.5 oz. (70 grams) MAX. .71 oz. (20 grams) MAX.
5. TOTAL WEIGHT:
6. PLUNGER WEIGHT:

Both Models Available with or without Plunger Stop.

INTERMITTENT DUTY CYCLE AT NOMINAL VOLTAGE IS 1 MINUTE MAXIMUM ON TIME AT 10% DUTY. PULSE DUTY CYCLE IS 100 MILLISECONDS ON AT 10% DUTY.

